



## **Westminster International University in Tashkent**

**A set of entrance exams on**

**Mathematics**

**2005-2007**

**Time allowed: One hour ten minutes**

**Answer all questions.**

**It is advised that you work quickly and that you leave behind questions that are taking you too long to answer.**

**You should only bring in writing material (pens, pencils, erasers, rulers).**

**No calculators are allowed.**

**All your rough calculations have to be presented. Answers with no evidence of calculations will not score any marks.**

**Use the blank pages of the exam paper to do your rough work.**

**Nothing should be removed from the exam room.**

**M11****Question 1**

Solve  $\frac{4}{x^2-1} + \frac{5}{x-1} = \frac{6}{x+1}$ .

Answer x =

**Question 2**

The curve with equation  $y = 3 + k \sin x$ , where  $k$  is a constant, passes through the point with coordinates  $\left(\frac{p}{2}, -1\right)$ .

a) Find the value of  $k$  and b) find the largest value of  $y$ .

Answer: a)  $k =$  ; b) max  $y =$

**Question 3**

Anna, Bakhrom, Caterina and Dildora have 27,000 Uzbek cym between them; Anna has three times as much as Caterina, and Bakhrom five times as much as Dildora; also, Anna and Bakhrom together have 5,000 cym less than eight times what Caterina has. Find how much each has.

Answer: Anna = , Bakhrom = , Caterina = , Dildora =

**Question 4**

- a) Solve the simultaneous equations  $x + y = 7$  and  $x^2 + y^2 = 49$ ;  
 b) Draw the graph of  $x + y = 7$ .

Answer: a)  $x =$       and  $y =$       or  $x =$       and  $y =$

**Question 5**

The sum of five numbers in arithmetic progression is 40 and the sum of their squares is 410; find the five numbers.

Answer: The 5 numbers are      ,      ,      ,      ,      ,

**Question 6**

An equilateral triangle has sides of length 6 meters. On each side of the triangle a square is drawn external to the triangle. Find the area of the complete figure.

$$\sqrt{3} = 1.73$$

Answer: Area is       $\text{m}^2$

**M12****Question 1**

Solve  $\frac{2}{x^2 + x - 2} + \frac{4}{x + 2} = 1$ .

Answer  $x =$  ,

**Question 2**

Find all angles  $0 \leq x \leq p$  for which a)  $\cos 3x = 0.5$  and b)  $\tan\left(x + \frac{p}{2}\right) = -1$

Answer a)  $x =$  or or ; b)  $x =$

**Question 3**

A number consists of three digits, the right-hand one being zero. If the left-hand and the middle digits are interchanged the number becomes smaller by 180; if the left-hand digit is halved and the middle and right-hand digits are interchanged the number becomes smaller by 454. Find the number.

Answer: The number is

**Question 4**

c) Solve the simultaneous equations

$$3x + 6y = 45$$

$$6x - 3y = 45$$

d) Draw the graph of the two lines above, clearly showing the point of intersection.

**Question 5**

The last term of an arithmetic progression is ten times the first, and the last but one term is equal to the sum of the 4<sup>th</sup> and the 5<sup>th</sup>. Find the number of terms.

Answer: a)  $x =$       and  $y =$

**Question 6**

ABCD is a trapezium with AB parallel to CD and  $BC=AD$ . The diagonals AC and BD meet at P. If angle  $ACD = 40^\circ$ , find angle ABD and angle APD.

Answer: Number of terms =

Answer: Angle ABD =      ; Angle APD =

**M13****Question 1**Solve  $x^2 + x - 12 = 0$ .**Question 2**Evaluate  $E = 3\log_{10}\left(\frac{5}{2}\right) + 2\log_{10}\left(\frac{3}{2}\right) - \log_{10}\left(\frac{5}{72}\right)$ .Answer  $x =$  or**Question 3**

A dealer bought a horse, expecting to sell it at a 10% profit, but he was forced to sell it for 5000 cym less than he expected. When he calculated what had happened, he found he had lost 15% on what the horse cost him. What did he pay for the horse?

Answer  $E =$ 

Answer: He paid cym for the horse

**Question 4**

- e) Solve the simultaneous equations  $x + 2y = 13$  and  $3x + y = 14$ ;
- f) Draw the graph of  $3x + y = 14$ .

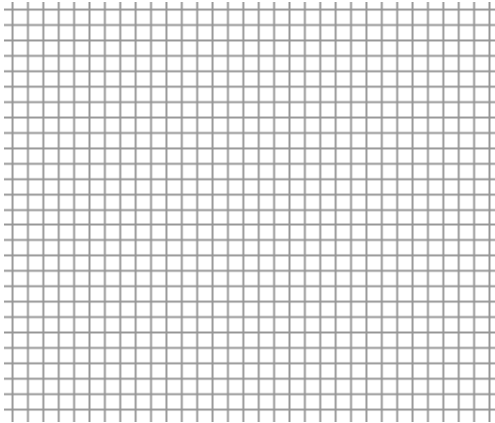

Answer: a)  $x =$       and  $y =$

**Question 5**

How many terms of the arithmetic progression 42, 39, 36... do we need to add up to 315?

Answer: Number of terms =

**Question 6**

If  $\tan(A+B) = 21$  and  $\tan A = 0.2$ , calculate  $\tan B$ .

Answer:  $\tan B =$

**M14****Question 1**

Solve  $\frac{\sqrt{x}-6}{\sqrt{x}-1} = \frac{\sqrt{x}-8}{\sqrt{x}+7}$ .

**Question 2**

Evaluate  $E = \frac{3^{n+4} - 6 \times 3^{n+1}}{7 \times 3^{n+3}}$  and  $F = \frac{\left(\frac{a^{-1}b^3}{\sqrt[3]{a}}\right)^{\frac{5}{4}}}{\sqrt[6]{\frac{a^2\sqrt{b}}{b^2}}}$ .

Answer x =

**Question 3**

Evaluate  $E = \cos\left(\frac{p}{6} + a\right)\cos\left(\frac{p}{6} - a\right) - \sin\left(\frac{p}{6} + a\right)\sin\left(\frac{p}{6} - a\right)$

Answer E = and F =

Answer: E =

**Question 4**

- g) Solve the simultaneous equations  $7x + 2y = 47$  and  $5x - 4y = 1$ ;
- h) Draw the graph of these two lines. Show the point of intersection clearly.

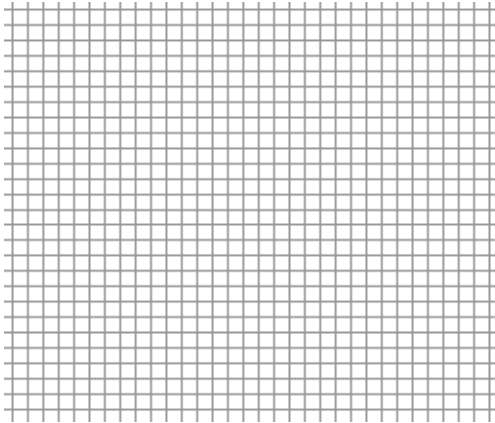

Answer: a)  $x =$       and  $y =$

**Question 5**

Find three numbers in arithmetic progression whose sum is 21 and whose product is 315.

Answer: The three numbers are      ,      and

**Question 6**

ABC is an isosceles triangle with  $AB = AC$ . The bisector of angle  $\angle ABC$  meets AC at D. If  $BD = BC$ , find the size of the angles of the triangle.

Answer: Angles are  $\angle ABC = \angle ACB =$       and  $\angle BAC =$

**M15****Question 1**Solve  $x^3 - 7x^2 + 12x = 0$ .Answer:  $x =$  , and**Question 2**Evaluate  $E = \frac{2\frac{4}{5} + 1\frac{1}{4}}{3\frac{3}{5}} - \frac{6}{16}$ ,  $F = \frac{2a-5}{4a^2-10a}$  and  $G = 2E - F$   
 $\frac{3a+2}{9a^2+6a}$ Answer  $E =$  ,  $F =$  and  $G =$ **Question 3**

At the beginning of the academic year a student bought  $x$  books at a total cost of 80000 Uzbek cym. A few days later he bought 5 more books for a further 25000 cym. He found that the second purchase had reduced the overall average cost per book by 1000 cym. How many books did he buy altogether?

Answer: He bought \_\_\_\_\_ books

**Question 4**

- i) Solve the simultaneous equations  $x + y = 2$  and  $2x + y = 3$ ;
- j) Draw the graph of these two lines. Show the point of intersection clearly.

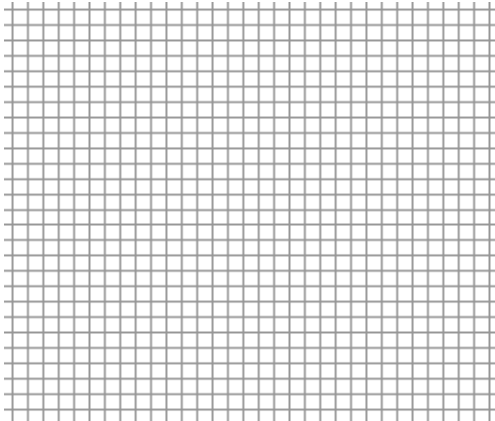

Answer: a)  $x =$       and  $y =$

**Question 5**

The fourth term of an arithmetic progression is 15 and the fifteenth term is 59. Find a) the first term and b) the sum of the first four terms.

Answer: a) First term is      b) The sum is

**Question 6**

The triangles below are similar as indicated for each pair. Find  $x$  and  $y$  in each case:

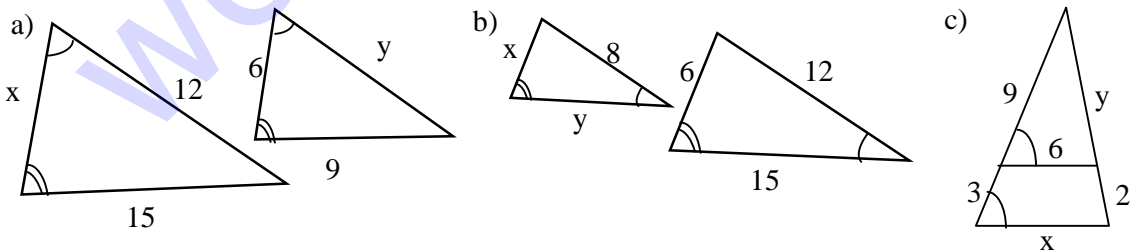

Diagram not to scale

Answer: a)  $x =$       ,  $y =$       b)  $x =$       ,  $y =$       c)  $x =$       ,  $y =$

**M16****Question 1**

If  $x = 4$  is a solution of  $x^2 - 2x + c = 0$ , find the second solution.

**Question 2**

Find the value of  $E \times F$  when  $E = \frac{4 \times 3^{n+2} + 6 \times 3^{n+1} - 3^{n+2}}{3 \times 3^n}$  and  $F = \frac{\frac{3^{n+5}}{3^{n+4} - 3^{n+2}}}{\frac{3}{2^3}}$ .

Answer:  $x =$ **Question 3**

A travelling salesman spends 125,000cym to buy two kinds of cloth at 2,500cym and 2,000cym per meter. He manages to sell it all at 2,150cym per meter and make a profit of 3.2%. How many meters of each cloth did he buy.

Answer:  $E \times F =$ 

Answer: He bought .....m and .....m of cloth

**Question 4**

- k) Solve the simultaneous equations  $y + 2x = 7$  and  $y = x - 2$ ;  
 l) Draw the graph of these two lines. Show the point of intersection clearly.

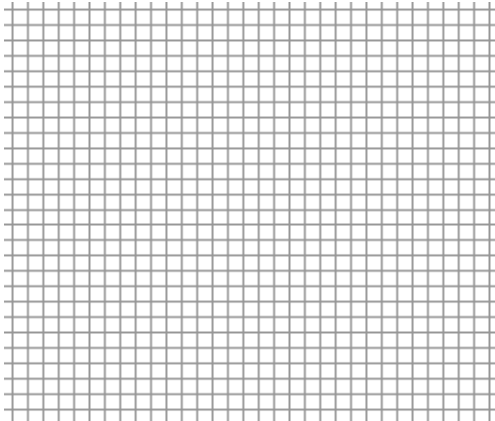

Answer: a)  $x =$       and  $y =$

**Question 5**

List the first three terms of the arithmetic progression whose 8<sup>th</sup> term is 51 and the sum of the first 17 terms is 986.

Answer: The three numbers are      ,      and

**Question 6**

- a) Find the angles A, B, C of the triangle ABC.

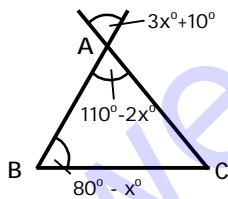

- b) Triangles  $A_1B_1C_1$  and  $A_2B_2C_2$  are equal. Find angles  $\varphi$  and  $\omega$ .

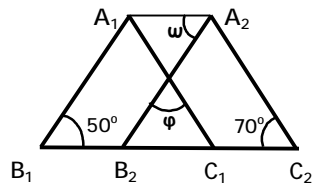

Answer: a) Angles are  $A =$       ,  $B =$       , and  $C =$       )  $\omega =$       and  $\varphi =$

**M17****Question 1**

Find the two integer solutions of  $x^2 + 100x - 1221 = 0$ .

Answer: The roots are  $x =$                       and  $x =$

**Question 2**

Given  $\log 2 \approx 0.3$ , find the value of

$$A = 3\log 2 + 3\log(2 + \sqrt{2}) + 3\log(2 + \sqrt{2 + \sqrt{2}}) + 3\log(2 - \sqrt{2 + \sqrt{2}}).$$

Answer:  $A =$

**Question 3**

Dilshod, Sasha and Berzot went fishing and caught 27 fish between them. Sasha caught half as many as Berzot. Berzot and Sasha together caught 25% more than Dilshod did. How many fish did each catch?

Answer: Dilshod caught                      , Sasha caught                      and Berzot caught                      fish.

**Question 4**

Plot the graph of  $(x-10)(x-40) = 0$  for values of  $x$  between  $-10$  and  $+50$ .

$x$	-10	0	10	20	30	40	50
$x^2 - 50x + 400$							

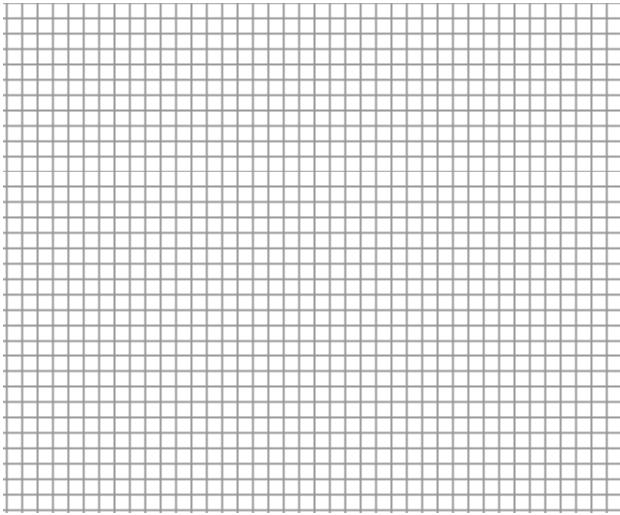

**Question 5**

Find the sum of the first 99 odd numbers  $1 + 3 + 5 + 7 + 9 + 11 + \dots$

Answer: The sum is

**Question**

Find the value of the angles  $\alpha$ ,  $\beta$  and  $\gamma$  in the figure below where  $AB$  is parallel to  $CD$

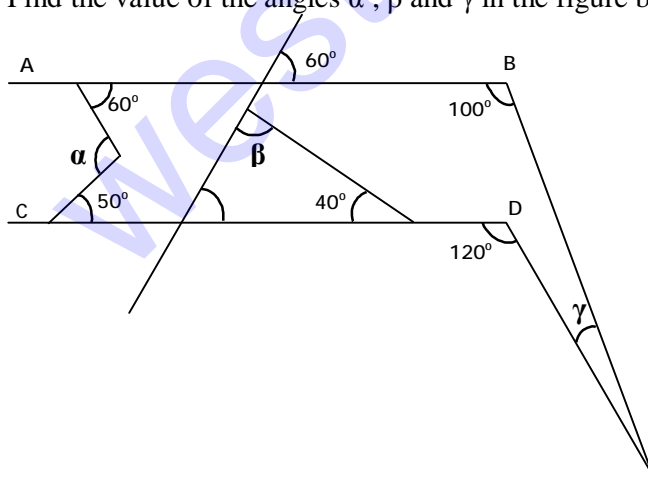

Answer:  $\alpha^\circ =$  ,  $\beta^\circ =$  and  $\gamma^\circ =$

**M18****Question 1**

Solve the quadratic equation  $3x^2 + (x-1)^2 + 10(x-1) + 9 = 0$ .

Answer: The roots are  $x =$                       and  $x =$

**Question 2**

Find the value of  $A = 6\log 2 + 2\log 5 - \log 16$  and  $B = \frac{1}{2}\log 25 + \frac{1}{3}\log 8 + \frac{1}{5}\log 32 - \log 2 + 3\log 10$ .

Answer:  $A =$                       and  $B =$

**Question 3**

Umid bought a number of apples at 3 for 100cym and five-sixths of that number at 4 for 100cym. He sold them at 4 for 150cym and made a profit of 350cym. How many apples did Umid buy?

Answer: Umid bought                      apples

**Question 4**

In an experiment, the following measurements were made:

X	5	10	15	30	40	60	90
Y	30	50	70	130	200	250	370

Theoretical predictions indicate that X and Y are related linearly. It is also thought that one measurement is incorrect. Draw a suitable graph to a) find the wrong point and b) predict the value of Y for X = 75.

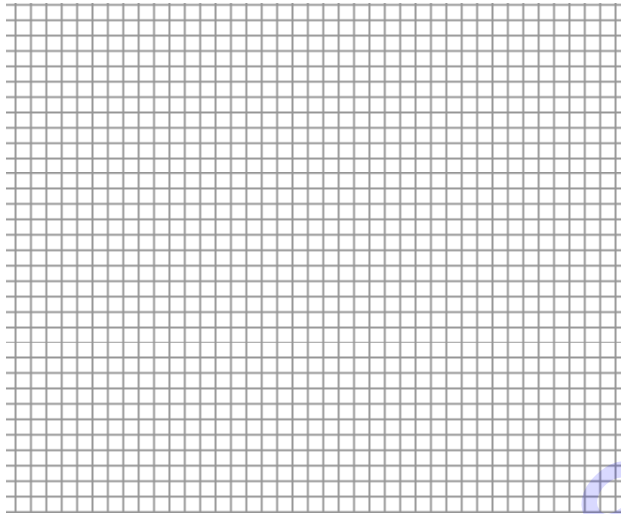

**Question 5**

Find the sum of the first 100 even numbers  $2 + 4 + 6 + 8 + 10 + 12 + \dots$

Answer: The sum is

**Question**

Find the value of the angles  $\alpha$ ,  $\beta$  and  $\gamma$  in the figure below where AB is parallel to CD

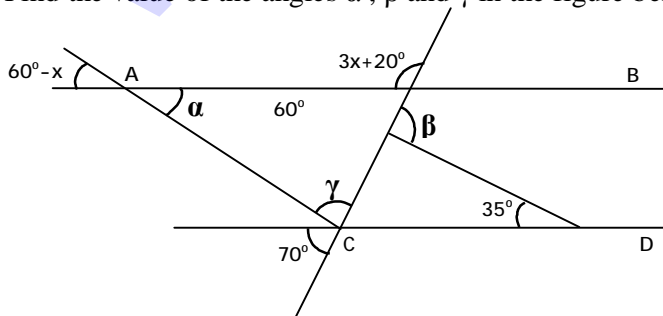

Answer:  $\alpha^\circ =$  ,  $\beta^\circ =$  and  $\gamma^\circ =$

**M19****Question 1**

Find the value of  $p$  if the equation  $(x^2 - 8)p^2 + (x + 2)p = -2x$  has  $x = 3$  as a root.

Answer:  $p =$       or

**Question 2**

Simplify as much as possible the expression

$$E = \left( \frac{a^4 + b^4}{b^6} \right) \left( \frac{1}{a-b} - \frac{1}{a+b} - \frac{2b}{a^2 + b^2} - \frac{4b^3}{a^4 + b^4} \right)$$

Answer:  $E =$

**Question 3**

The ages of a boy and a girl add up to 20. In 4 years time the age of the girl will be three times as much as the age of the boy. How old will each be in 2 years time?

Answer: In 2 years time the boy will be      years old and the girl      years old.

**Question 4**

Draw the graphs of  $y = 2 - x$  and  $y = 2x - x^2$ . Where do these graphs meet?  
 Make sure you indicate clearly in the diagram the points where the graphs meet.

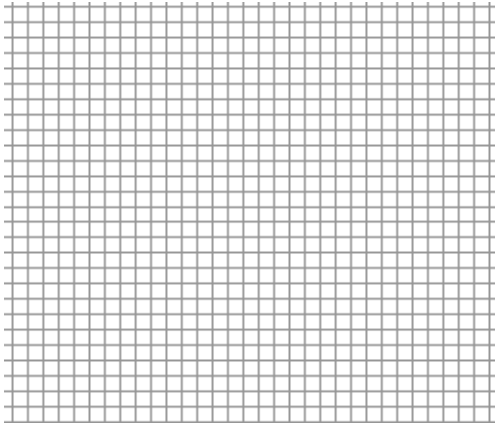

Answer: The graphs meet at a)  $x =$  ,  $y =$  and at b)  $x =$  ,  $y =$

**Question 5**

How many terms of the geometric progression  $1 - 2 + 4 - 8 + 16 - 32 + \dots$  do we need to add up to  $\frac{1}{3}(2^{15} + 1)$ ?

Answer: Number of terms =

**Question 6**

The diagram below is a rough sketch of a garden. Triangle ABC is a right angled triangle with  $B = 90^\circ$  and  $AB = 3\text{m}$ . Triangle ACD is also a right angled triangle with  $C = 90^\circ$ ,  $AD = 13\text{m}$  and  $CD = 12\text{m}$ . Find the area of the garden, in square meters.

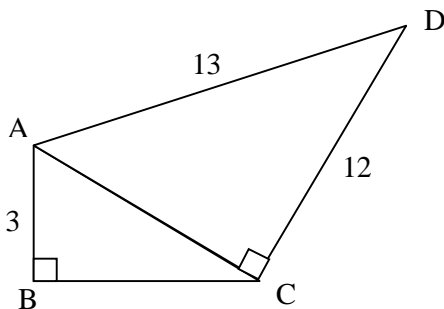

Answer: The area is  $\quad \text{m}^2$ .

**M20**

**Question 1**

Solve the equation  $(2x - 3)^2 - 2x - 3 = 0$ .

Answer:  $x =$       or

**Question 2**

Solve the equation  $3^{x+3} - 26 \cdot 3^x = 9^{x-1}$ .

Answer:  $x =$

**Question 3**

Draw the graphs of  $y = x^2 - 2x + 1$  and  $y = 2x - x^2$  for  $0 \leq x \leq 2$  on the grid below. From your graph estimate the distance between the two points where the graphs meet.

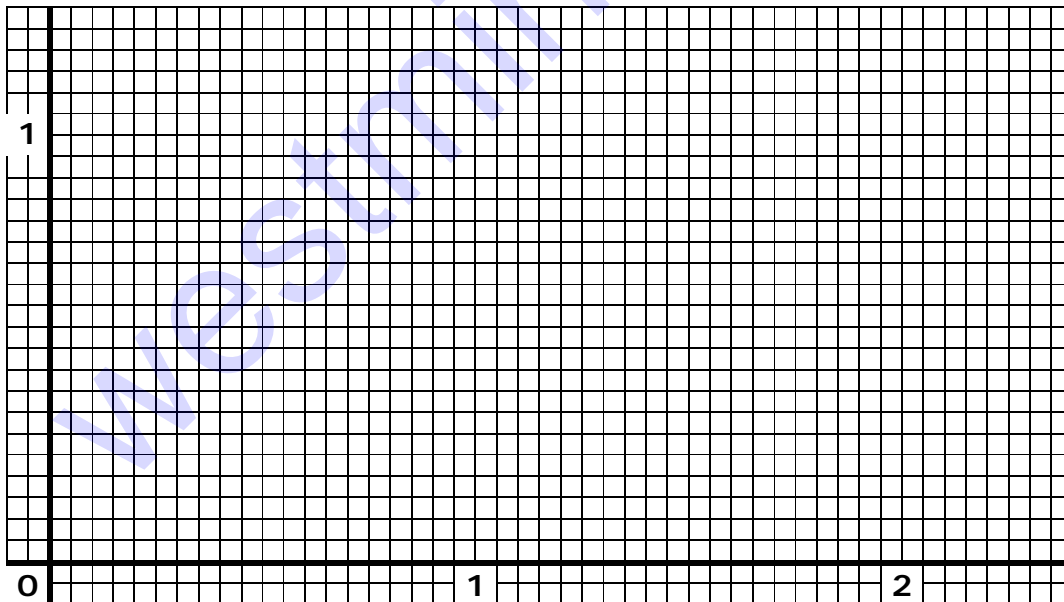

Answer: Distance between meeting points is approximately      units



## M21

**Question 1**

If  $x = 5$  is a root of  $x^3 - 9x^2 + 8x + 60$ , find the other two roots.

Answer:  $x =$       and  $x =$

**Question 2**

Evaluate  $A = \frac{2a(a+1)(a+2)}{a^2+a-2} - a - \frac{(a^2+a+2)(a+1)}{a^2-1}$ .

Answer:  $A =$

**Question 3**

Dilshod, Sasha and Berzod opened a business together. Dilshod put 160,000 of his Uzbek soums to start the business, Sasha put 280,000 and Berzod 200,000. After six months Sasha took out half the money he put in. After a year the business profits where 68,400. How much of that profit should each partner get?

Answer: Dilshod gets      , Sasha gets      , and Berzod get      Uzbek soums

**Question 4**

Plot the lines  $y = 4x - 9$  and  $y = 3 - 2x$ , showing clearly the point where they intersect.

**Question 5**

Find the first term of an arithmetic progression when the sum of the third and seventh term is 40 and the sum of the sixth and eighth term is 56.

Answer: The first term is .

**Question 6**

ABCD is a trapezium with  $AB=CD$ ,  $BC \parallel AD$ ,  $AD = 25$  and the angle  $ABD = 90^\circ$ . If E is on AD such that BE is perpendicular to AD and  $AE = 9$ , find the perimeter of ABCD.

Answer:

M28

**Question 1**

Solve  $2x(x^2 + 2x - 35) - 7(x^2 + 2x - 35) = 0$ .

Answer:  $x =$  or**Question 2**

Evaluate:  $A = \frac{2}{4a^2 - \frac{8(a^3 - 1)}{2a + \frac{2}{a+1}}}$ .

Answer:  $A =$ **Question 3**

In 4 years from now Anna will be  $\frac{2}{3}$  (two thirds) of Berzot's present age. In 11 years from now Berzot will be double Sasha's present age. 14 years ago Sasha was half Anna's present age. Find their present ages.

Answer: Anna is , Berzot is and Sasha is years old.

**Question 4**

Plot the lines  $x + y = 7$  and  $2x + 3y = 11$ , showing clearly the point where they intersect.

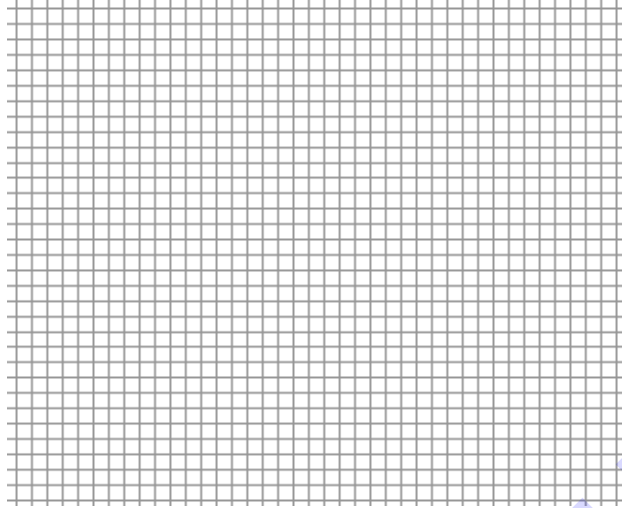

**Question 5**

- a) Find the sum of all the even numbers between 1 and 51.
- b) Find the sum of all the even numbers between 1 and 2007. Even is  $2n$ .

Answer: The sums are a)                      and b)

**Question 6**

In the figure we have  $AB \parallel CD$ ,  $AC \perp BD$ ,  $AB = 5\text{cm}$ ,  $AC = 28\text{ m}$  and  $CD = 30\text{ m}$ . Find  $AE$  and  $BE$ .

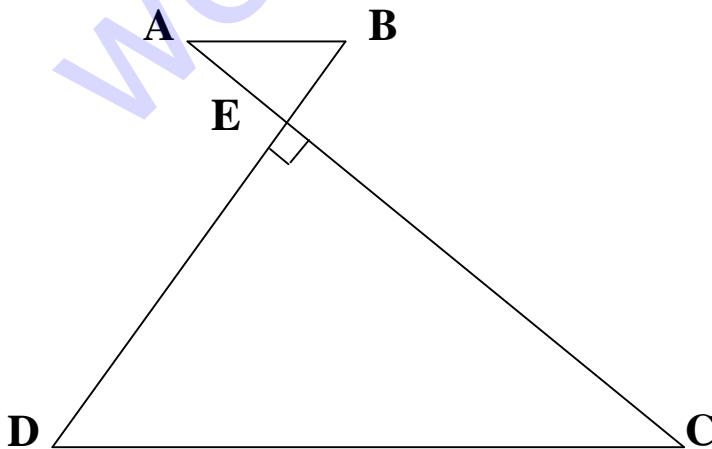

Answer:  $AE =$                       and  $BE =$